

This form is the approved form that must be used in accordance with section 10 of the *Building Act 1975* and sections 73 and 77 of the Building Regulation 2021 (Design-specification certificate) stating that an aspect of building work or specification will, if installed or carried out as stated in this form, comply with the building assessment provisions.

Additional explanatory information is included in the Appendix at the end of this form.

1. Property description

This section need only be completed if details of street address and property description are applicable.

E.g. in the case of (standard/generic) pool design/shell manufacture and/or patio and carport systems this section may not be applicable.

Where applicable, the description must identify all land the subject of the application.

The lot and plan details (e.g. SP/RP) are shown on title documents or a rates notice.

If the plan is not registered by title, provide previous lot and plan details.

Street address	N/A		
	Suburb/locality	N/A	
State	N/A Choose an item.	Postcode	N/A
Lot and plan details (<i>attach list if necessary</i>)			
N/A			
Local government area the land is situated in			
N/A			

2. Description of aspect/s certified

Clearly describe the extent of work covered by this certificate, e.g. all structural aspects of the steel roof beams.

National Construction Code (NCC) 2022 Volumes One and Two Building Code of Australia (BCA):

Volume One,

- D3D17 – Barriers to prevent falls,

- For domestic and residential installations in Class 2, 3 and Class 4 parts of buildings for AS/NZS 1170.1:2002, Table 3.3 – Minimum Imposed Actions for Barriers, “A” & “C3” where no part of ‘Glass Panel’ or ‘Sectional Glass Panel’ (non-heat soaked) is glazed more than 5m from the finished floor or ground level; and may only protect a fall of less than 5m; and,
- For ‘Glass Panel Applications – One (1) BASE RAIL SUPPORT for each balustrade section’, installed in accordance with *Peak® Aluminium Balustrade – Installation Guide (I101PB_InstallGuide_V7)*, the Design Ultimate Wind Pressure, calculated in accordance with AS/NZS 1170.2, shall not exceed ± 1.56 kPa for a maximum post spacing (W) of 1.20m (maximum Glass Panel width 1025mm); and,
- For *Glass Panel Applications – Two (2) BASE RAIL SUPPORT(S) FOR GLASS PANEL for each balustrade section*, installed in accordance with *Peak® Aluminium Balustrade – Installation Guide For Glass Panels With Base Rail Supports For Glass Panel (PB_BRSGP_InstallGuide_V3)*, the Design Ultimate Wind Pressure, calculated in accordance with AS/NZS 1170.2, shall not exceed; ± 4.02 kPa for a maximum post spacing (W) of 1.20m (maximum Glass Panel width 1025mm); and, ± 2.50 kPa for a maximum post spacing (W) of 1.80m (maximum Glass Panel width 1625mm). For maximum rail length/Glass Panel width wind pressure limitations see *System Drawings* (Sheet 4 of 17); and,
- For ‘Sectional Glass Panel’ (152.4mm panel width, 100mm spacing) the Design Ultimate Wind resistance calculated in accordance with AS/NZS 1170.2 does not exceed 62 m/s, see *System Drawings* (Sheet 7 of 17); and,
- For ‘Wide Balusters’ or ‘Standard Balusters’, the Design Ultimate Wind resistance calculated in accordance with AS/NZS 1170.2 does not exceed 84 m/s, see *System Drawings* (Sheets 1&2 of 17).

- **D3D22 - Handrails,**
For domestic and residential applications in Class 2, 3 & Class 4 parts of buildings only.
- **D3D23 - Fixed platforms, walkways, stairways and ladders**
For domestic and residential applications in Class 2, 3 & Class 4 parts of buildings only.
For the case of 'Glass Panel' and/or 'Sectional Glass' applications no part of the glass shall be glazed more than 5m from the finished floor or ground level.

**Volume Two & ABCB Housing Provisions,
- H5D3 & Part 11.3.1 – Barriers and Handrails**

- For domestic and residential installations in Class 1 & 10 buildings for AS/NZS 1170.1:2002, Table 3.3 – Minimum Imposed Actions for Barriers, “A”; and,
- For 'Glass Panel' or 'Sectional Glass Panel' (non-heat soaked) not glazed more than 5m from the finished floor or ground level, and only protect a fall of less than 5m; and,
- For 'Glass Panel Applications – One (1) BASE RAIL SUPPORT for each balustrade section', installed in accordance with *Peak® Aluminium Balustrade – Installation Guide (I101PB_InstallGuide_V7)*, the Design Ultimate Wind Pressure, calculated in accordance with AS/NZS 1170.2, shall not exceed ± 1.56 kPa for a maximum post spacing (W) of 1.20m (maximum *Glass Panel* width 1025mm). This wind pressure, in accordance with AS/NZS 1170.2, is equivalent to AS 4055 Table 3.5(A) ultimate strength pressures for walls including Wind Classifications N1w and N2w; and,
- For *Glass Panel Applications – Two (2) BASE RAIL SUPPORT(S) FOR GLASS PANEL for each balustrade section*, installed in accordance with *Installation Guide for Glass Panels with Base Rail Supports For Glass Panel (PB_BRSGP_InstallGuide_V3)*, the Design Ultimate Wind Pressure, calculated in accordance with AS/NZS 1170.2, shall not exceed; ± 4.02 kPa for a maximum post spacing (W) of 1.20m (maximum *Glass Panel* width 1025mm); and, ± 2.50 kPa for a maximum post spacing (W) of 1.80m (maximum *Glass Panel* width 1625mm). These wind pressures in accordance with AS/NZS 1170.2, are equivalent to AS 4055 Table 3.5(A) ultimate strength pressures for walls including Wind Classifications N1w, N2w, N3w, N4w, C1w & C2w. For maximum rail length/Glass Panel width wind pressure limitations see *System Drawings* (Sheet 4 of 17); and,
- For 'Sectional Glass Panel' (152.4mm panel width, 100mm spacing) the Design Ultimate Wind resistance calculated in accordance with AS/NZS 1170.2 does not exceed 62 m/s. This includes AS 4055 Table 3.5(A) ultimate strength pressures for walls for Wind Classifications N1w, N2w, N3w, N4w, C1w and C2w, see *System Drawings* (Sheet 7 of 17); and,
- For 'Wide Balusters' or 'Standard Balusters', the Design Ultimate Wind resistance calculated in accordance with AS/NZS 1170.2 does not exceed 84 m/s, this includes AS 4055 Table 3.5(A) ultimate strength pressures for walls including Wind Classifications N1w, N2w, N3w, N4w, N5w, C1w, C2w and C3w, see *System Drawings* (Sheets 1&2 of 17).

3. Basis of certification

Detail the basis for giving the certificate and the extent to which tests, specifications, rules, standards, codes of practice and other publications were relied upon.

Review of independent third party NCC-2022 Appraisal and Certification of components and system compliance to relevant Australian Standards and NCC-2022 Performance Requirements.

Review of independent third-party testing by NATA registered laboratory.

Review of independent third-party accreditation of glazing components to AS/NZS 2208.

Review of glazing components and assemblies to AS 1288.

Review of manufacturers' literature including installation instructions.

Conditions:

- i. Installation of the *Peak® Aluminium Balustrade* shall be in accordance with:
 - a. *Peak® Aluminium Balustrade - Installation Guide (I101PB_InstallGuide_V7)*; or, *Peak® Aluminium Balustrade – Installation Guide For Glass Panels With Base Rail Supports For Glass Panel (PB_BRSGP_InstallGuide_V3)*; and,
 - b. *Peak® Aluminium Balustrade – System Drawings (Report Drawings – PAB AUSTRALIA 20230418)*.
- ii. Product selection and installation shall be made by a competent person who is conversant with the application and technical aspects of the product and has ready access to the relevant technical information related to the product installation.
- iii. Particular attention shall be paid to the structural adequacy of all connections to supporting structures designed by others. All supporting structures shall be independently verified as capable of providing the necessary structural support to the *Peak® Aluminium Balustrade*.

Limitations:

- i. This certificate specifically excludes any assessment of the suitability of *Peak® Aluminium Balustrade* and/or *Peak® Aluminium Handrail* as a swimming pool safety barrier.
- ii. This certificate does not deal with any aspect of the performance of gate components or their installation (detailed on page 14 of *Peak® Aluminium Balustrade - Installation Guide* (I101PB_InstallGuide_V7)).
- iii. This certification does not deal with materials safety, site safety or safe work practices in any form. Specification and installation should only be considered in conjunction with reference to appropriate hazards.
- iv. This certification does not deal with the quality assurance aspects of the manufacturing, transportation and installation processes.

4. Reference documentation

Clearly identify any relevant documentation, e.g. numbered structural engineering plans.

Specifications:	Prepared by:	Date:
<i>Peak® Aluminium Balustrade - Installation Guide</i> (I101PB_InstallGuide_V7)	Peak Products Corporation	undated
<i>Peak® Aluminium Balustrade – Installation Guide For Glass Panels With Base Rail Supports For Glass Panel</i> (PB_BRSGP_InstallGuide_V3)	Peak Products Corporation	Undated
<i>Peak® Aluminium Balustrade – System Drawings</i> (Report Drawings – PAB AUSTRALIA 20230418) (see Attachment 1)	Peak Products Corporation	2023/04/18
Fastener Schedule (see Attachment 2)	Acronem Consulting Australia	April 2023

Test Reports:	Prepared by:	Date:
Test Report MT-19-0362, Load Testing of Aluminium Balustrade Posts	Melbourne Testing Services	2 May 2019
Report 20190951M01, Mechanical Testing Report	AlfaTest	22 May 2019
Report 20191023M01, Mechanical Testing Report	AlfaTest	15/05/2019
Test Report 2016-094-R1, Peak Aluminium Balustrade System Load Tests to AS/NZS 1170. 1 for Peak Products Corporation.	Ian Bennie Associates	7 February 2019
Test Report 22-1314-A, Load Testing of Peak Products Aluminium Balustrade - Stair Assembly	Melbourne Testing Services	20 January 2023
Test Report 22-1314-B, Load Testing of Peak Products Aluminium Balustrade – Angle Bracket Assembly	Melbourne Testing Services	16 February 2023

Engineering:	Prepared by:	Date:
REPORT No: ACA – 200305 220421, Peak® Aluminium Balustrade: NCC 2022 Volumes One & Two, Building Code of Australia – Appraisal – Barrier (domestic and residential activities)	Acronem Consulting Australia	21 April 2023

5. Building certifier reference number and building development approval number

Building certifier reference number	Building development application number (<i>if available</i>)
-------------------------------------	---

6. Appointed competent person details

Under Part 6 of the Building Regulation 2021 a person must be assessed as a competent for the type of work (design-specification) by the relevant building certifier.

Name (in full)	Cameron Chick BE(Civil), Ph.D(Engineering)		
Company name (if applicable)	Acronem Consulting Australia Pty Ltd		
Contact person	Cameron Chick		
Business phone number	0437407176	Mobile	0437407176
Email address	cameron@acronem.com.au		
Postal address	39 Admiralty Avenue		
	Suburb/locality	Tanilba Bay	
State	NSW	Postcode	2319
Licence class or registration type (if applicable)	Structural		
Licence or registration number (if applicable)	RPEQ 15370		

7. Signature of appointed competent person

This certificate must be signed by the individual assessed and appointed by the building certifier as competent to give design-specification help.

Signature		Date	26/04/2023
-----------	--	------	------------

LOCAL GOVERNMENT USE ONLY

Date received	Click or tap to enter a date.	Reference number/s	
---------------	-------------------------------	--------------------	--

Appendix – explanatory information

IMPORTANT NOTE: It is an offence for a competent person to give a building certifier a document, including this form, that the person knows or reasonably suspects, is false or misleading.

Who can complete this certificate? (section 10 of the *Building Act 1975* (Building Act) and 73 and 77 of the Building Regulation 2021 (BR 2021).

A building certifier can accept from a competent person (design-specification) a certificate stating that the competent person has assessed the building design or specification for the aspect of building work, and it will, if installed or carried out under the certificate, comply with the building assessment provisions, including any relevant standards and codes.

Schedule 10 of the BR 2021 defines *building design or specification* as any material, system, method of building or other thing related to the design of or specifications for building work.

When completing the certificate, a competent person is required under section 77 of the BR 2021 to include the basis for giving the certificate and state the extent to which the competent person has relied on tests, specifications, rules, standards, codes of practice or other publications.

What is the purpose of this form? (section 10 of the Building Act and sections 73 and 77 of the BR2 2021)

The information in this form informs the building certifier's decision making when they are assessing a building development application, issuing the building development approval for the building work the subject of the certificate (form) and when amending the building development approval due to the receipt of updated aspect information such as glazing or truss specifications or revised excavation drawings.

Can a manufacturer or supplier give this Form 15?

A building certifier can accept this form from a manufacturer or supplier who the certifier has decided is a competent person (design-specification).

A manufacturer or supplier of building materials can give this form if they have undertaken the design component for the product. For example a window manufacturer who designs, constructs and supplies the windows to industry could give this form.

Competent person (section 10 of the *Building Act 1975* and Part 6 of the BR 2021)

A building certifier must assess and decide to appoint an individual as a competent person before they can accept design-specification help.

When deciding whether a person can be a competent person, the building certifier must assess the person having regard to their experience, qualifications and skills and ensure the person holds a licence or registration if required.

The building certifier is required to keep detailed records about what was considered when appointing a competent person.

For further information about assessment of someone as a competent person refer to the **Guideline for the assessment of competent persons**.

What is required if a manufacturer or supplier did not do the design work for the product?

A manufacturer or supplier who is not part of the design process may give the construction contractor, builder, competent person or the building certifier evidence of suitability such as a product technical statement under Part A5 of the Building Code of Australia (BCA), for an aspect or material stating that it is compliant with the relevant reference documents in the BCA i.e. the applicable Australian Standard/s.

What if there is not enough space for all the supporting material/documents?

Items 2, 3 and 4 requires the competent person to clearly identify the extent of the assessment that was undertaken for aspect/s of work identified in this form.

For instance, there is provision for material such as specifications, standards, codes or other relevant publications to be referenced in the form. However, if the space in the form is not sufficient to accommodate all of this material, you can create and refer to additional material in an addendum or attachment to the form.

The form is the Microsoft Word version, that you can download and edited to include additional material in the relevant parts of the form. **Note:** that editing the form in the Microsoft Word version may cause the relevant boxes to expand and increase the length of the document. This is acceptable and does not change the approved form, provided the section text (description on the left-hand side of the page) is not altered.

Appointed competent person (design-specification) – (sections 34 and 36 of the BR 2021)

A building certifier must assess and decide to appoint an individual as a competent person before they can, as a competent person, give design-specification help. The building certifier is required to keep detailed records about what was considered when appointing a competent person.

A building certifier must be satisfied that an individual is competent to give the type of help having regard to the individual's experience, qualifications and skills and if required by law to hold a licence or registration, that the individual is appropriately registered or licensed.

An individual is appointed as competent to give design-specification help on or from a particular day.

For further information about assessment of someone as a competent person refer to the **Guideline for the assessment of competent persons**.

PRIVACY NOTICE

The Department of Energy and Public Works is collecting personal information as required under the *Building Act 1975*. This information may be stored by the Department, and will be used for administration, compliance, statistical research and evaluation of building laws. Your personal information will be disclosed to other government agencies, local government authorities and third parties for purposes relating to administering and monitoring compliance with the *Building Act 1975*. Personal information will otherwise only be disclosed to third parties with your consent or unless authorised or required by law.

Attachment 1: System Drawings (Report Drawings – PAB AUSTRALIA 20230418)

SKU (White)	SKU (Black)	SKU (Silver)	Description
70000	70001	70004	End Post
70010	70011	70014	Mid Post
70020	70021	70024	Corner Post
70050	70051	70054	Stair Post
70100	70101	70104	1.2m Hand and Base Rail
70110	70111	70114	1.8m Hand and Base Rail
70200	70201	70204	1.2m Standard Baluster & Spacer Kit
70210	70211	70214	1.8m Standard Baluster & Spacer Kit
70220	70221	70224	Stair Rail Kit Standard Balusters
70260	70261	70264	1.8m Standard Stair Baluster & Spacer Kit
70300	70301	70304	1.2m Wide Baluster & Spacer Kit
70310	70311	70314	1.8m Wide Baluster & Spacer Kit
70320	70321	70324	Stair Rail Kit Wide Balusters
70360	70361	70364	1.8m Wide Stair Baluster & Spacer Kit
70940	70940	70940	1.2m Glass Gasket
70941	70941	70941	1.8m Glass Gasket
70718	70714	70716	Sectional Glass Kit with Clear Glass Panels
70719	70715	70717	Sectional Glass Kit with Tinted Glass Panels
70832	70832	70832	Glass Panel 425mm x 857mm x 6mm
70835	70835	70835	Glass Panel 500mm x 857mm x 6mm
70838	70838	70838	Glass Panel 575mm x 857mm x 6mm
70841	70841	70841	Glass Panel 650mm x 857mm x 6mm
70844	70844	70844	Glass Panel 725mm x 857mm x 6mm
70847	70847	70847	Glass Panel 800mm x 857mm x 6mm
70850	70850	70850	Glass Panel 875mm x 857mm x 6mm
70853	70853	70853	Glass Panel 950mm x 857mm x 6mm
70856	70856	70856	Glass Panel 1025mm x 857mm x 6mm
70859	70859	70859	Glass Panel 1100mm x 857mm x 6mm
70862	70862	70862	Glass Panel 1175mm x 857mm x 6mm
70865	70865	70865	Glass Panel 1250mm x 857mm x 6mm
70868	70868	70868	Glass Panel 1325mm x 857mm x 6mm
70871	70871	70871	Glass Panel 1400mm x 857mm x 6mm
70874	70874	70874	Glass Panel 1475mm x 857mm x 6mm
70877	70877	70877	Glass Panel 1550mm x 857mm x 6mm
70880	70880	70880	Glass Panel 1625mm x 857mm x 6mm
70900	70901	70904	Universal Bracket
70910	70911	70914	Base Rail Supports for Glass Panel
70920	70921	70924	Wall Bracket
70930	70931	70934	Stair Bracket
70950	70951	70954	Horizontal Angle Bracket

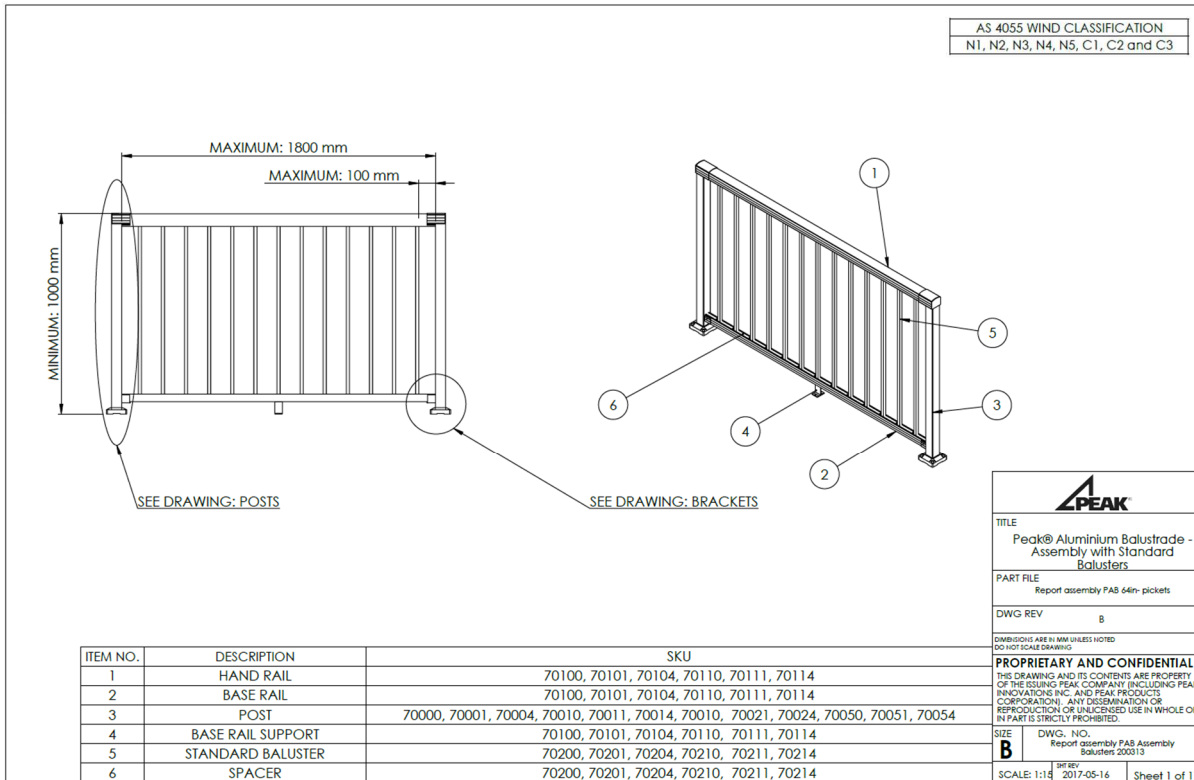

AS 4055 WIND CLASSIFICATION
N1, N2, N3, N4, N5, C1, C2 and C3

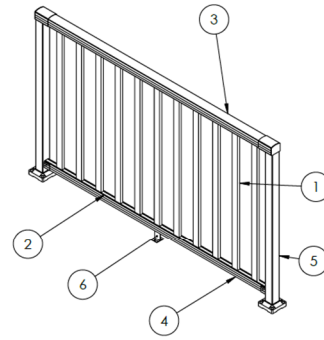
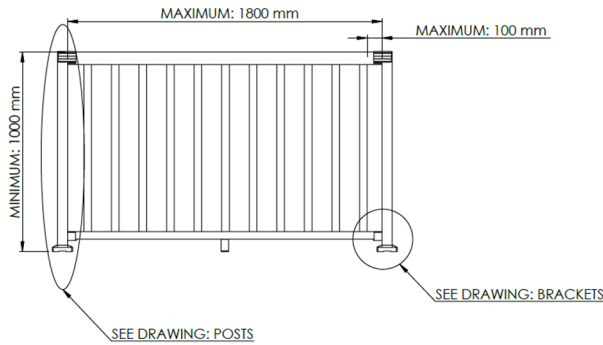

ITEM NO.	DESCRIPTION	SKU
1	WIDE BALUSTER	70300, 70301, 70304, 70310, 70311, 70314
2	SPACER	70300, 70301, 70304, 70310, 70311, 70314
3	HAND RAIL	70100, 70101, 70104, 70110, 70111, 70114
4	BASE RAIL	70100, 70101, 70104, 70110, 70111, 70114
5	POST	70000, 70001, 70004, 70010, 70011, 70014, 70020, 70021, 70024, 70050, 70051, 70054
6	BASE RAIL SUPPORT	70100, 70101, 70104, 70110, 70111, 70114

PEAK

TITLE
Peak® Aluminium Balustrade - Assembly with Wide Balusters

PART FILE
Report assembly PAB 64in-wide pickets

DWG REV
B

DIMENSIONS ARE IN MM UNLESS NOTED
DO NOT SCALE DRAWING

PROPRIETARY AND CONFIDENTIAL
THIS DRAWING AND ITS CONTENTS ARE PROPERTY OF THE ISSUING PEAK COMPANY INCLUDING PEAK INNOVATIONS INC. AND PEAK PRODUCTS CORPORATION. ANY DISSEMINATION OR REPRODUCTION OR UNLICENSED USE IN WHOLE OR IN PART IS STRICTLY PROHIBITED.

SIZE DWG. NO.
B Report assembly PAB Assembly Wide Balusters 200313

SCALE: 1:15 2017-05-16 Sheet 2 of 17

POST MOUNT SECTION

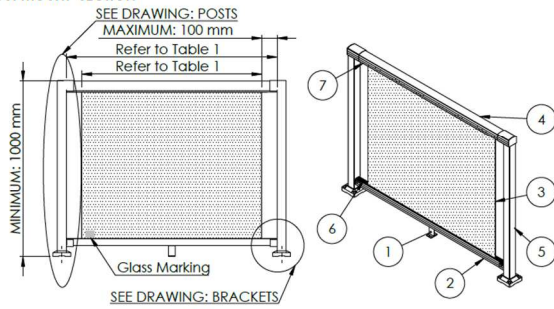

WALL MOUNT SECTION

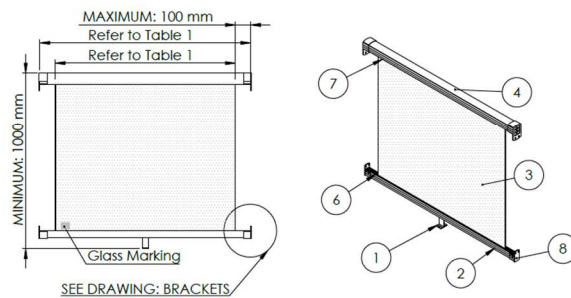

GLASS MARKING



TABLE 1

Wind Pressure (kPa)	0.94	1.56
AS 4055 Wind Classification	N1w	N2w
Maximum Rail Length (mm)	1200	1200
Maximum Glass Panel Width (mm)	1025	1025

ITEM NO.	DESCRIPTION	SKU
1	BASE RAIL SUPPORT	70100, 70101, 70104
2	BASE RAIL	70100, 70101, 70104
3	GLASS PANEL	70832, 70835, 70838, 70841, 70844, 70847, 70850, 70853, 70856
4	HANDRAIL	70100, 70101, 70104
5	POSTS	70000, 70001, 70004, 70010, 70011, 70014, 70020, 70021, 70024, 70051, 70054, 70050
6	LOWER GLASS GLASKET	70940
7	UPPER GLASS GLASKET	70940
8	WALL BRACKET	70920, 70921, 70924

PEAK

TITLE
Peak® Aluminium Balustrade - Assembly with Glass Panel

PART FILE
Report assembly PAB - 1.2m span-glass panel

DWG REV
E

DIMENSIONS ARE IN MM UNLESS NOTED
DO NOT SCALE DRAWING

PROPRIETARY AND CONFIDENTIAL
THIS DRAWING AND ITS CONTENTS ARE PROPERTY OF THE ISSUING PEAK COMPANY INCLUDING PEAK INNOVATIONS INC. AND PEAK PRODUCTS CORPORATION. ANY DISSEMINATION OR REPRODUCTION OR UNLICENSED USE IN WHOLE OR IN PART IS STRICTLY PROHIBITED.

SIZE DWG. NO.
B Report assembly PAB Assembly Glass Panel 230323

SCALE: 1:15 2017-05-16 Sheet 3 of 17

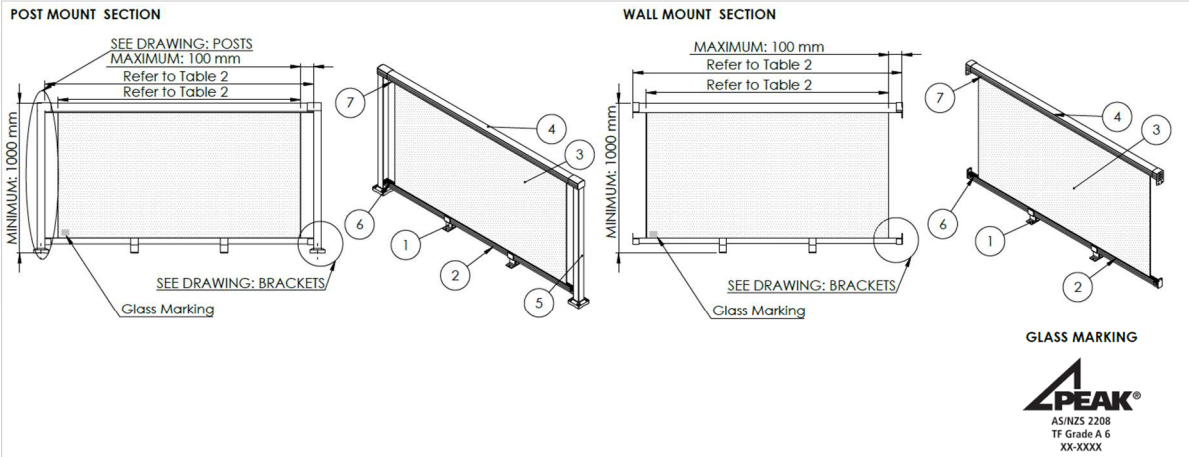

TABLE 2

Wind Pressure (kPa)	0.94	1.56	2.03	3.01	2.7	4.02
AS 4055 Wind Classification	N1w	N2w	N3w	N4w	C1w	C2w
Maximum Rail Length (mm)	1800	1800	1800	1500	1650	1250
Maximum Glass Panel Width (mm)	1625	1625	1625	1325	1475	1025

ITEM NO.	DESCRIPTION	SKU
1	BASE RAIL SUPPORT FOR GLASS PANEL	70910, 70911
2	BASE RAIL	70100, 70101, 70104, 70110, 70111, 70114
3	GLASS PANEL	70832, 70835, 70838, 70841, 70844, 70847, 70850, 70853, 70856, 70859, 70862, 70865, 70868, 70871, 70874, 70877, 70880
4	HANDRAIL	70100, 70101, 70104, 70110, 70111, 70114
5	POSTS	70000, 70001, 70004, 70010, 70011, 70014, 70020, 70021, 70024, 70051, 70054, 70050
6	LOWER GLASS GLASKET	70940, 70941
7	UPPER GLASS GLASKET	70940, 70941
8	WALL BRACKET	70920, 70921, 70924

GLASS MARKING

AS/NZS 2208
TF Grade A 6
XX-XXXX

PEAK

TITLE: Peak® Aluminium Balustrade - Assembly with Glass Panel and Base Rail Supports for Glass

PART FILE: Report assembly PAB - 1.8m span-glass panel

DWG REV: E

DIMENSIONS ARE IN MM UNLESS NOTED DO NOT SCALE DRAWINGS

PROPRIETARY AND CONFIDENTIAL
THIS DRAWING AND ITS CONTENTS ARE PROPERTY OF THE ISSUING PEAK COMPANY (INCLUDING PEAK INNOVATIONS INC. AND PEAK PRODUCTS CORPORATION). ANY DISSEMINATION OR REPRODUCTION OR UNLICENSED USE IN WHOLE OR IN PART IS STRICTLY PROHIBITED.

SIZE: DWG. NO. B
Report assembly PAB Assembly Glass Panel 2023023

SCALE: 1:15 2017-05-16 Sheet 4 of 17

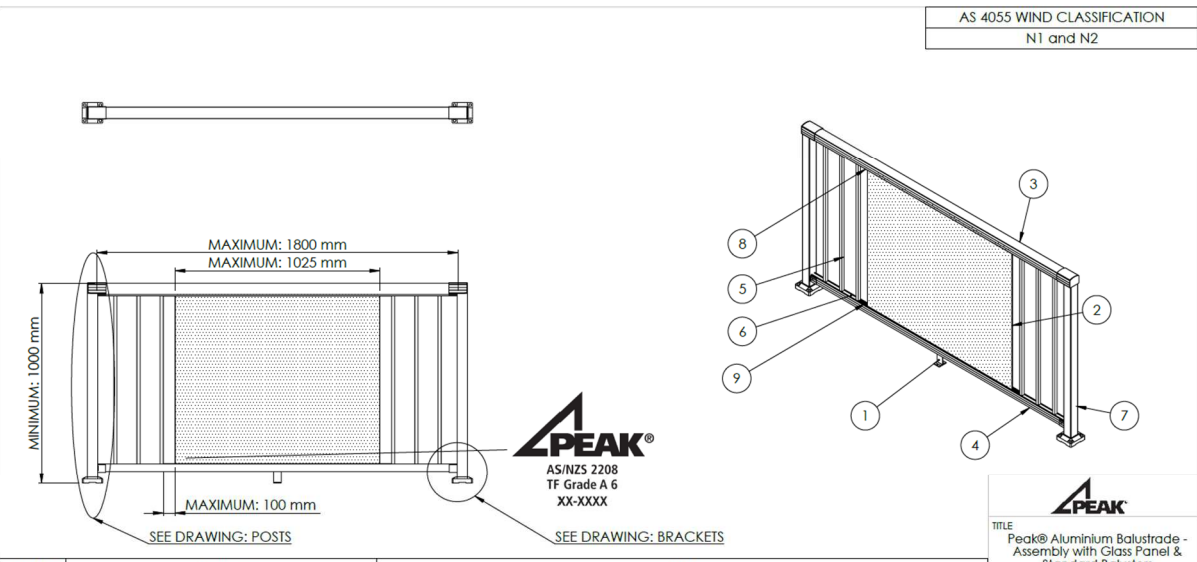

ITEM NO.	DESCRIPTION	SKU
1	BASE RAIL SUPPORT	70100, 70101, 70104, 70110, 70111, 70114
2	GLASS PANEL	70832, 70835, 70838, 70841, 70844, 70847, 70850, 70853, 70856
3	HANDRAIL	70100, 70101, 70104, 70110, 70111, 70114
4	BASE RAIL	70100, 70101, 70104, 70110, 70111, 70114
5	STANDARD BALUSTER	70200, 70201, 70204, 70210, 70211, 70214
6	SPACER	70200, 70201, 70204, 70210, 70211, 70214
7	POSTS	70000, 70001, 70004, 70010, 70011, 70014, 70020, 70021, 70024, 70051, 70054, 70050
8	UPPER GLASS GASKET	70940
9	LOWER GLASS GASKET	70940

AS 4055 WIND CLASSIFICATION
N1 and N2

AS/NZS 2208
TF Grade A 6
XX-XXXX

PEAK

TITLE: Peak® Aluminium Balustrade - Assembly with Glass Panel & Standard Balusters

PART FILE: Report assembly PAB - 1.8m span-glass panel with balusters

DWG REV: C

DIMENSIONS ARE IN MM UNLESS NOTED DO NOT SCALE DRAWINGS

PROPRIETARY AND CONFIDENTIAL
THIS DRAWING AND ITS CONTENTS ARE PROPERTY OF THE ISSUING PEAK COMPANY (INCLUDING PEAK INNOVATIONS INC. AND PEAK PRODUCTS CORPORATION). ANY DISSEMINATION OR REPRODUCTION OR UNLICENSED USE IN WHOLE OR IN PART IS STRICTLY PROHIBITED.

SIZE: DWG. NO. B
Report assembly PAB Assembly Glass Panel with balusters 2023023

SCALE: 1:15 2017-05-16 Sheet 5 of 17

AS 4055 WIND CLASSIFICATION
N1 and N2

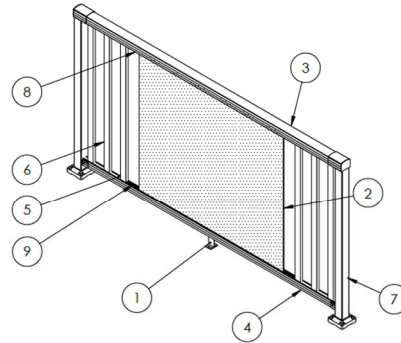
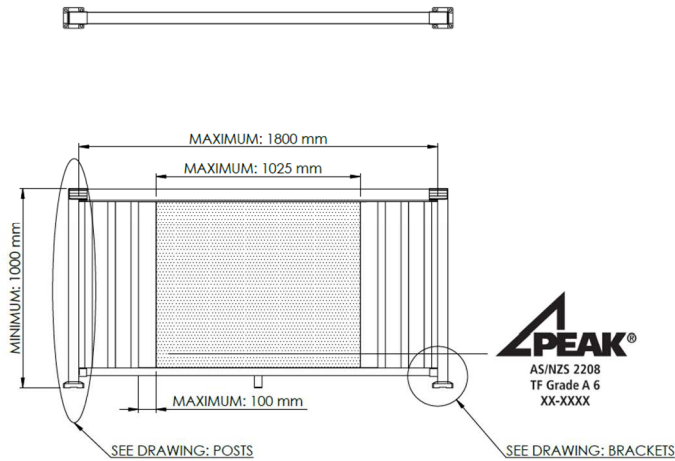

ITEM NO.	DESCRIPTION	SKU
1	BASE RAIL SUPPORT	70100, 70101, 70104, 70110, 70111, 70114
2	GLASS PANEL	70832, 70835, 70838, 70841, 70844, 70847, 70850, 70853, 70856
3	HANDRAIL	70100, 70101, 70104, 70110, 70111, 70114
4	BASE RAIL	70100, 70101, 70104, 70110, 70111, 70114
5	SPACER	70300, 70301, 70304, 70310, 70311, 70314
6	WIDE BALUSTER	70300, 70301, 70304, 70310, 70311, 70314
7	POST	70000, 70001, 70004, 70010, 70011, 70014, 70020, 70021, 70024, 70051, 70054, 70050
8	UPPER GLASS GASKET	70940
9	LOWER GLASS GASKET	70940

PEAK

TITLE
Peak® Aluminium Balustrade -
Assembly with Glass Panel &
Wide Balusters

PART FILE
Report assembly PAB - 1.8m span-glass
panel with wide balusters

DWG REV
C

DIMENSIONS ARE IN MM UNLESS NOTED
DO NOT SCALE DRAWING

PROPRIETARY AND CONFIDENTIAL
THIS DRAWING AND ITS CONTENTS ARE PROPERTY
OF THE ISSUING PEAK COMPANY (INCLUDING PEAK
INNOVATIONS INC. AND PEAK PRODUCTS
CORPORATION). ANY DISSEMINATION OR
REPRODUCTION OR UNLICENSED USE IN WHOLE OR
IN PART IS STRICTLY PROHIBITED.

SIZE DWG. NO.
B Report assembly PAB Assembly Glass
Panel with wide balusters 20200323
REV

SCALE: 1:15 2017-05-16 Sheet 6 of 17

AS 4055 WIND CLASSIFICATION
N1, N2, N3, N4, C1 and C2

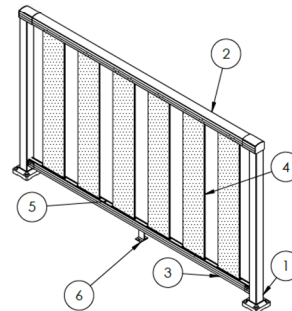
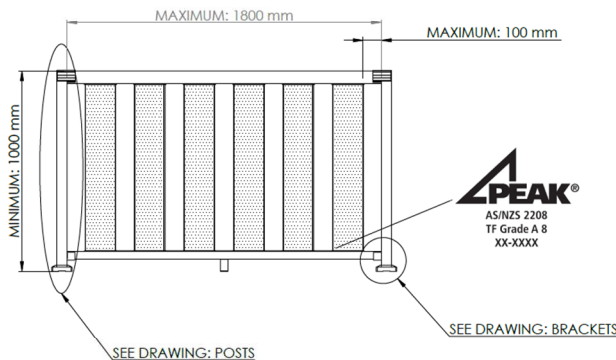

ITEM NO.	DESCRIPTION	SKU
1	POSTS	70000, 70001, 70004, 70010, 70011, 70014, 70020, 70021, 70024, 70050, 70051, 70054
2	HAND RAIL	70100, 70101, 70104, 70110, 70111, 70114
3	BASE RAIL	70100, 70101, 70104, 70110, 70111, 70114
4	SECTIONAL GLASS KIT	70714, 70715, 70716, 70717, 70718, 70719
5	SPACER	70714, 70715, 70716, 70717, 70718, 70719
6	BASE RAIL SUPPORT	70100, 70101, 70104, 70110, 70111, 70114

PEAK

TITLE
Peak® Aluminium Balustrade -
Assembly with Sectional Glass

PART FILE
Report assembly PAB glass pickets

DWG REV
C

DIMENSIONS ARE IN MM UNLESS NOTED
DO NOT SCALE DRAWING

PROPRIETARY AND CONFIDENTIAL
THIS DRAWING AND ITS CONTENTS ARE PROPERTY
OF THE ISSUING PEAK COMPANY (INCLUDING PEAK
INNOVATIONS INC. AND PEAK PRODUCTS
CORPORATION). ANY DISSEMINATION OR
REPRODUCTION OR UNLICENSED USE IN WHOLE OR
IN PART IS STRICTLY PROHIBITED.

SIZE DWG. NO.
B Report assembly PAB Assembly
Sectional Glass 230418
REV

SCALE: 1:15 2017-05-16 Sheet 7 of 17

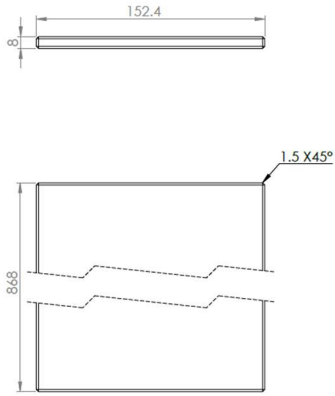

GLASS PANEL
SCALE 1:2

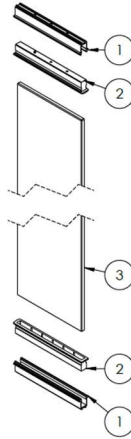

ITEM NO.	DESCRIPTION	SKU
1	Glass Panel Holder	
2	Glass Panel Gasket	70714, 70715, 70716, 70717, 70718, 70719
3	Glass Panel	

PEAK

TITLE
Peak® Aluminium Balustrade -
Sectional Glass Components

PART FILE
FAB-glass-picket

DWG REV
C

DIMENSIONS ARE IN MM UNLESS NOTED
DO NOT SCALE DRAWING

PROPRIETARY AND CONFIDENTIAL
THIS DRAWING AND ITS CONTENTS ARE PROPERTY
OF THE ISSUING PEAK COMPANY (INCLUDING PEAK
INNOVATIONS INC. AND PEAK PRODUCTS
CORPORATION). ANY DISSEMINATION OR
REPRODUCTION OR UNLICENSED USE IN WHOLE OR
IN PART IS STRICTLY PROHIBITED.

SIZE DWG. NO.
B Report - Sectional Glass PAB 230418

DWG REV 2017-05-16
SCALE: 1:2 Sheet 8 of 17

SEE DRAWING: POSTS

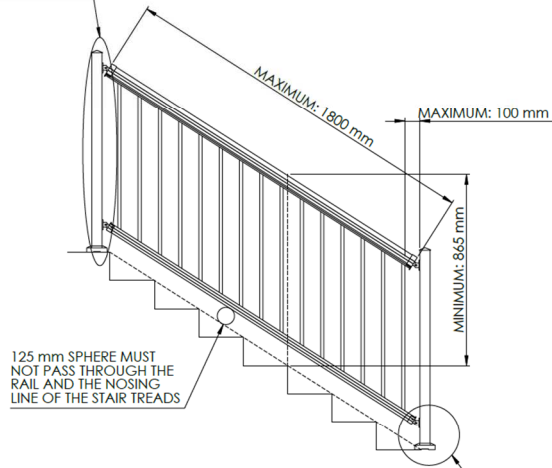

SEE DRAWING: BRACKETS

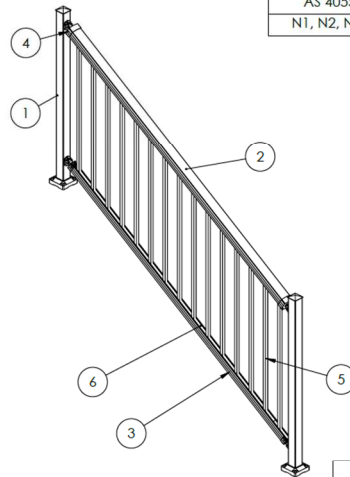

AS 4055 WIND CLASSIFICATION
N1, N2, N3, N4, N5, C1, C2 and C3

ITEM NO.	DESCRIPTION	SKU
1	POST	70000, 70001, 70004, 70050, 70051, 70054
2	HAND RAIL	70100, 70101, 70104, 70110, 70111, 70114
3	BASE RAIL	70100, 70101, 70104, 70110, 70111, 70114
4	UNIVERSAL BRACKET	70900, 70901, 70904
5	STANDARD STAIR BALUSTER	70260, 70261, 70264
6	STAIR SPACER	70260, 70261, 70264

PEAK

TITLE
Peak® Aluminium Balustrade -
Stair Assembly with Balusters

PART FILE
Report assembly - stair - pickets PAB

DWG REV
B

DIMENSIONS ARE IN MM UNLESS NOTED
DO NOT SCALE DRAWING

PROPRIETARY AND CONFIDENTIAL
THIS DRAWING AND ITS CONTENTS ARE PROPERTY
OF THE ISSUING PEAK COMPANY (INCLUDING PEAK
INNOVATIONS INC. AND PEAK PRODUCTS
CORPORATION). ANY DISSEMINATION OR
REPRODUCTION OR UNLICENSED USE IN WHOLE OR
IN PART IS STRICTLY PROHIBITED.

SIZE DWG. NO.
B Report assembly PAB Stair Balusters AUS
200313

DWG REV 2017-05-16
SCALE: 1:15 Sheet 9 of 17

AS 4055 WIND CLASSIFICATION
N1, N2, N3, N4, N5, C1, C2 and C3

SEE DRAWING: POSTS

125 mm SPHERE MUST NOT PASS THROUGH THE RAIL AND THE NOSING LINE OF THE STAIR TREADS

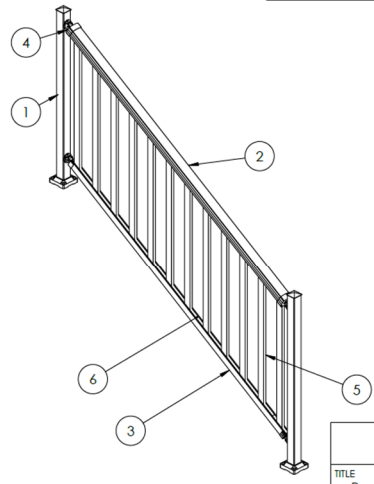
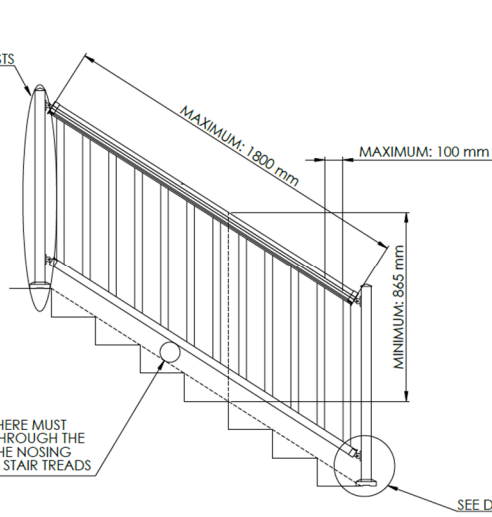

ITEM NO.	DESCRIPTION	SKU
1	POST	70000, 70001, 70004, 70050, 70051, 70054
2	HAND RAIL	70100, 70101, 70104, 70110, 70111, 70114
3	BASE RAIL	70100, 70101, 70104, 70110, 70111, 70114
4	UNIVERSAL BRACKET	70900, 70901, 70904
5	WIDE STAIR BALUSTER	70360, 70361, 70364
6	STAIR SPACER	70360, 70361, 70364

PEAK

TITLE
Peak® Aluminium Balustrade - Stair Assembly with Wide Balusters

PART FILE
Report assembly - stair - wide pickets PAB

DWG REV
8

DIMENSIONS ARE IN MM UNLESS NOTED
DO NOT SCALE DRAWINGS

PROPRIETARY AND CONFIDENTIAL
THIS DRAWING AND ITS CONTENTS ARE PROPERTY OF THE ISSUING PEAK COMPANY (INCLUDING PEAK INNOVATIONS INC. AND PEAK PRODUCTS CORPORATION). ANY DISSEMINATION OR REPRODUCTION OR UNLICENSED USE IN WHOLE OR IN PART IS STRICTLY PROHIBITED.

SIZE
B

DWG. NO.
Report assembly PAB Stair Wide Balusters AUS 200313

SCALE: 1:14
REV: 2017-05-16
Sheet 10 of 17

AS 4055 WIND CLASSIFICATION
N1, N2, N3, N4, N5, C1, C2 and C3

SEE DRAWING: POSTS

125 mm SPHERE MUST NOT PASS BETWEEN RAMP RISE AND BOTTOM RAIL

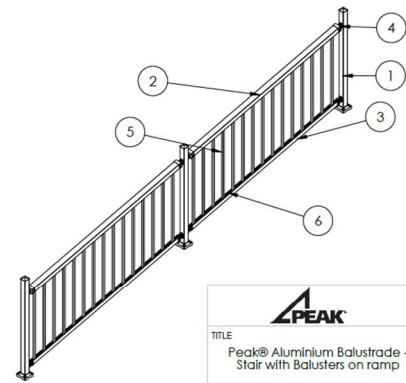
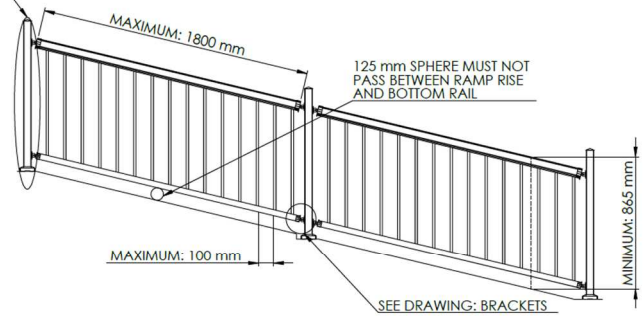

ITEM NO.	DESCRIPTION	SKU
1	POST	70000, 70001, 70004, 70050, 70051, 70054
2	HAND RAIL	70100, 70101, 70104, 70110, 70111, 70114
3	BASE RAIL	70100, 70101, 70104, 70110, 70111, 70114
4	UNIVERSAL BRACKET	70900, 70901, 70904
5	STANDARD STAIR BALUSTER	70260, 70261, 70264
6	STAIR SPACER	70260, 70261, 70264

PEAK

TITLE
Peak® Aluminium Balustrade - Stair with Balusters on ramp

PART FILE
Report assembly - stair - pickets PAB ramp

DWG REV
A

DIMENSIONS ARE IN MM UNLESS NOTED
DO NOT SCALE DRAWINGS

PROPRIETARY AND CONFIDENTIAL
THIS DRAWING AND ITS CONTENTS ARE PROPERTY OF THE ISSUING PEAK COMPANY (INCLUDING PEAK INNOVATIONS INC. AND PEAK PRODUCTS CORPORATION). ANY DISSEMINATION OR REPRODUCTION OR UNLICENSED USE IN WHOLE OR IN PART IS STRICTLY PROHIBITED.

SIZE
B

DWG. NO.
Report assembly PAB Stair Ramp

SCALE: 1:14
REV: 2017-05-16
Sheet 11 of 17

AS 4055 WIND CLASSIFICATION
N1, N2, N3, N4, N5, C1, C2 and C3

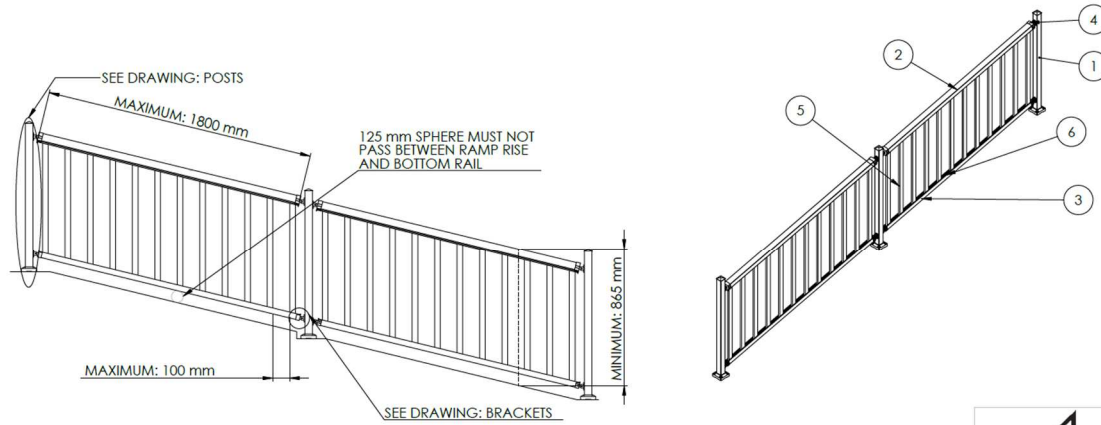

ITEM NO.	DESCRIPTION	SKU
1	POST	70000, 70001, 70004, 70050, 70051, 70054
2	HAND RAIL	70100, 70101, 70104, 70110, 70111, 70114
3	BASE RAIL	70100, 70101, 70104, 70110, 70111, 70114
4	UNIVERSAL BRACKET	70900, 70901, 70904
5	WIDE STAIR BALUSTER	70360, 70361, 70364
6	STAIR SPACER	70360, 70361, 70364

PEAK

TITLE
Peak® Aluminium Balustrade - Stair with Wide Balusters on ramp

PART FILE
Report assembly - stair - wide pickets PAB ramp

DWG REV
A

DIMENSIONS ARE IN MM UNLESS NOTED
DO NOT SCALE DRAWINGS

PROPRIETARY AND CONFIDENTIAL
THIS DRAWING AND ITS CONTENTS ARE PROPERTY OF THE ISSUING PEAK COMPANY INCLUDING PEAK INNOVATIONS INC. AND PEAK PRODUCTS CORPORATION. ANY DISSEMINATION OR REPRODUCTION OR UNLICENSED USE IN WHOLE OR IN PART IS STRICTLY PROHIBITED.

SIZE DWG. NO.
B Report assembly PAB Stair Ramp

SCALE: 1:16 2017-05-16 Sheet 12 of 17

AS 4055 WIND CLASSIFICATION
N1, N2, N3, N4, N5, C1, C2 and C3

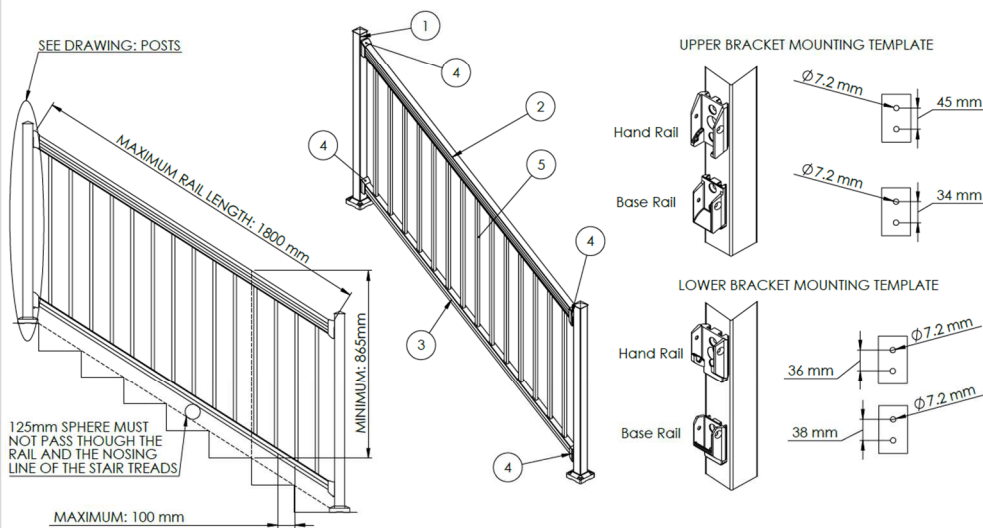

ITEM NO.	DESCRIPTION	SKU
1	POST	70000, 70001, 70004, 70050, 70051, 70054
2	HAND RAIL	70220, 70221, 70224
3	BASE RAIL	70220, 70221, 70224
4	STAIR BRACKETS	70220, 70221, 70224, 70930, 70931, 70934
5	STANDARD STAIR BALUSTER	70220, 70221, 70224

PEAK

TITLE
Peak® Aluminium Balustrade - Stair Rolling with Standard Balusters

PART FILE
PAB Stairs

DWG REV
A

DIMENSIONS ARE IN MM UNLESS NOTED
DO NOT SCALE DRAWINGS

PROPRIETARY AND CONFIDENTIAL
THIS DRAWING AND ITS CONTENTS ARE PROPERTY OF THE ISSUING PEAK COMPANY INCLUDING PEAK INNOVATIONS INC. AND PEAK PRODUCTS CORPORATION. ANY DISSEMINATION OR REPRODUCTION OR UNLICENSED USE IN WHOLE OR IN PART IS STRICTLY PROHIBITED.

SIZE DWG. NO.
B Report assembly PAB Stair Rail and Balusters

SCALE: 1:16 2017-05-16 Sheet 13 of 17

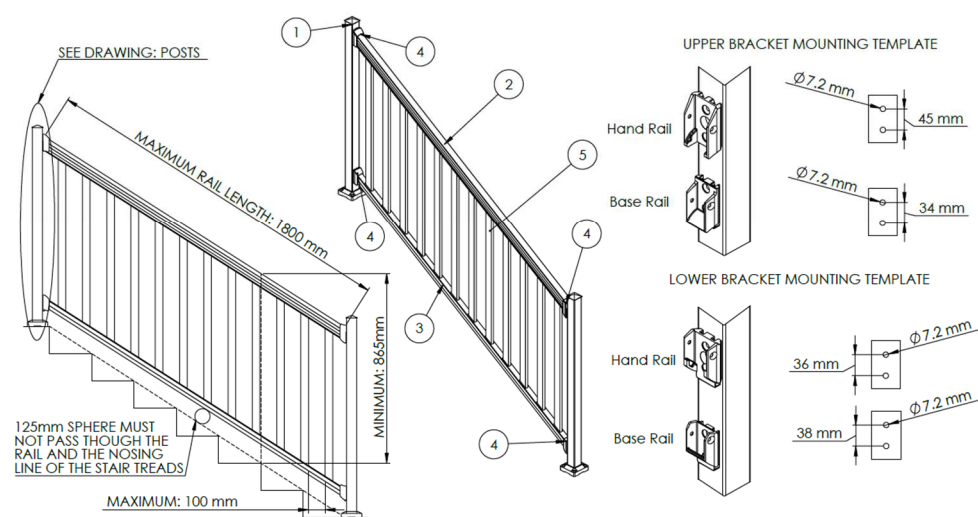

ITEM NO.	DESCRIPTION	SKU
1	POST	70000, 70001, 70004, 70050, 70051, 70054
2	HAND RAIL	70320, 70321, 70324
3	BASE RAIL	70320, 70321, 70324
4	STAIR BRACKETS	70320, 70321, 70324, 70930, 70931, 70934
5	WIDE STAIR BALUSTER	70320, 70321, 70324

PEAK

TITLE
Peak® Aluminium Balustrade - Stair Railing with Wide Balusters

PART FILE
PAB Stairs

DWG REV
A

DIMENSIONS ARE IN MM UNLESS NOTED DO NOT SCALE DRAWING

PROPRIETARY AND CONFIDENTIAL
THIS DRAWING AND ITS CONTENTS ARE PROPERTY OF THE ESUNG PEAK COMPANY (INCLUDING PEAK INNOVATIONS INC. AND PEAK PRODUCTS CORPORATION). ANY DISSEMINATION OR REPRODUCTION OR UNLICENSED USE IN WHOLE OR IN PART IS STRICTLY PROHIBITED.

SIZE
B DWG. NO.
Report assembly PAB Stair Rail and Wide Balusters

DATE REV
SCALE: 1:16 2017-05-16 Sheet 14 of 17

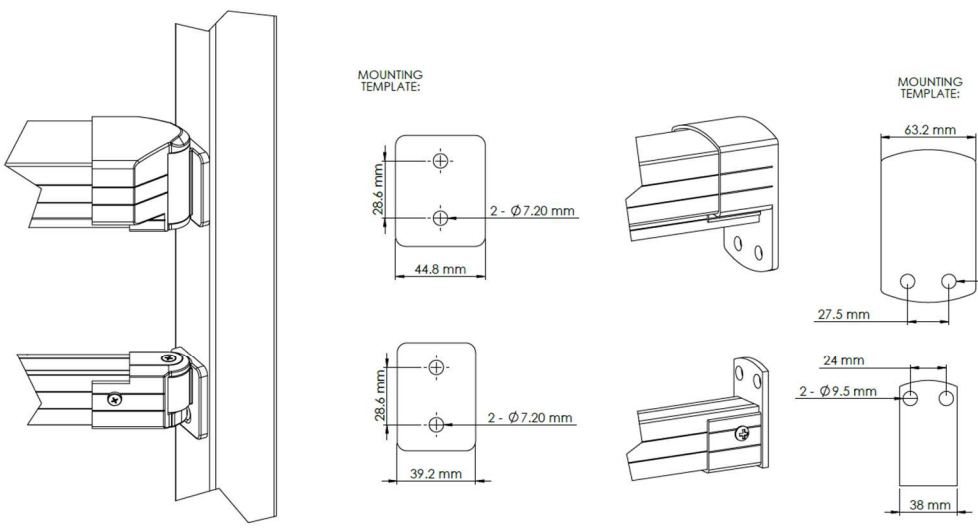

HORIZONTAL ANGLE BRACKET
SKU: 70950, 70951, 70954

WALL MOUNT BRACKETS
SKU: 70920, 70921, 70924

PEAK

TITLE
Peak® Aluminium Balustrade BRACKETS AND CONNECTORS

PART FILE
fig-wall-brackets

DWG REV
B

DIMENSIONS ARE IN MM UNLESS NOTED DO NOT SCALE DRAWING

PROPRIETARY AND CONFIDENTIAL
THIS DRAWING AND ITS CONTENTS ARE PROPERTY OF THE ESUNG PEAK COMPANY (INCLUDING PEAK INNOVATIONS INC. AND PEAK PRODUCTS CORPORATION). ANY DISSEMINATION OR REPRODUCTION OR UNLICENSED USE IN WHOLE OR IN PART IS STRICTLY PROHIBITED.

SIZE
B DWG. NO.
Report-brackets PAB 230323

DATE REV
SCALE: 1:2 2017-05-16 Sheet 15 of 17

UNIVERSAL BRACKET - STAIR APPLICATION

UNIVERSAL BRACKET - HORIZONTAL ANGLE APPLICATION

MOUNTING TEMPLATE:

$\text{Ø}12$

28

MOUNTING TEMPLATE:

$\text{Ø}12$

28

DESCRIPTION	SKU
Universal Bracket	70900, 70901, 70904

PEAK	
TITLE Peak® Aluminium Balustrade BRACKETS AND CONNECTORS	
PART FILE fig-brackets-stairs PAB	
DWG REV 8	
DIMENSIONS ARE IN MM UNLESS NOTED DO NOT SCALE DRAWING	
PROPRIETARY AND CONFIDENTIAL THIS DRAWING AND ITS CONTENTS ARE PROPERTY OF THE ISSUING PEAK COMPANY (INCLUDING PEAK INNOVATIONS INC. AND PEAK PRODUCTS CORPORATION). ANY DISSEMINATION OR REPRODUCTION OR UNLICENSED USE IN WHOLE OR IN PART IS STRICTLY PROHIBITED.	
SIZE B	DWG. NO. Report-brackets PAB 230023
SCALE: 1:3	SHEET REV: 2017-05-16 Sheet 16 of 17

END POST

MID POST

CORNER POST

STAIR POST

MOUNTING TEMPLATE

78

102

21.50

4 mounting holes:
 $\text{Ø} 11.25$ or $\text{Ø} 13$

DESCRIPTION	SKU
End Post	70000, 70001, 70004
Mid Post	70010, 70011, 70014
Corner Post	70020, 70021, 70024
Stair Post	70050, 70051, 70054

PEAK	
TITLE Peak® Aluminium Balustrade - POSTS	
PART FILE fig-post-corner PAB	
DWG REV 8	
DIMENSIONS ARE IN MM UNLESS NOTED DO NOT SCALE DRAWING	
PROPRIETARY AND CONFIDENTIAL THIS DRAWING AND ITS CONTENTS ARE PROPERTY OF THE ISSUING PEAK COMPANY (INCLUDING PEAK INNOVATIONS INC. AND PEAK PRODUCTS CORPORATION). ANY DISSEMINATION OR REPRODUCTION OR UNLICENSED USE IN WHOLE OR IN PART IS STRICTLY PROHIBITED.	
SIZE B	DWG. NO. Report-posts PAB 200313
SCALE: 1:6	SHEET REV: 2017-05-16 Sheet 17 of 17

Attachment 2: Fastener Schedule

The following summary information is provided on the fasteners used in conjunction with the Peak® Aluminium Balustrade. More detailed information regarding additional fastener requirements may be found in REPORT No: ACA – 200305 230421.

In all cases, the attachment of fasteners to a suitable concrete or timber supporting structure designed by others, must be independently verified for each installation.

Peak® Aluminium Balustrade

- **Post Base to Concrete:**

- o **Mechanical Anchoring:**
 - 4 x Ramset™ WERCS Ankascrew™ Anchor, M10x100 mm (AS10100WGM50), or
 - 4 x Ramset™ Ankascrew™ Anchor, M10x100 mm (AS10100GM), installed in accordance with Ramset™ Technical Data Sheet.
 - Minimum Concrete Strength 25 MPa,
 - Minimum Edge Distance 70 mm,
 - Minimum concrete embedment depth 72 mm.
- o **Chemical Anchoring:**
 - Design conditions in accordance with Ramset Design Calculator include:
 - Non-Cracked Concrete
 - Ramset “EPCON C8 Xtrem” Part No: C8450
 - Anchor Size: M10
 - Anchor Stud – Gr 5.8 or G316
 - Part No: CS10130, CS10130GH or CS10130SS
 - Minimum Edge Distance: 30mm
 - Min. Concrete Strength: 25MPa
 - Min. Hole Diameter / Depth: 12mm / 72mm
 - Min. Concrete thickness: 96mm

- **Post Base to Timber**

- o 4 x Coach Screw, M10 x (length) mm, Class 4.6 or Class 4.8 in accordance with AS/NZ 4291.1 and a hardness of 120-250 HV (67 HRB-22HRC) with:
 - Minimum embedment depth of the threaded portion of the coach screw into the side grain of the supporting structure is not less than,
 - 100 mm for JD3 (e.g. Seasoned, Mixed Australian Hardwoods),
 - 125 mm for J3 (e.g. Unseasoned, Mixed Australian Hardwoods),
 - 145 mm for JD4 (e.g. Seasoned, Mixed Softwood Species), or
 - 185 mm for J4 (e.g. Unseasoned, Pine, Radiata, Australia).
 - Minimum end distance (5D) 50 mm, see AS 1720.1 for definitions.
 - Minimum edge distance (4D) 40 mm, see AS 1720.1 for definitions.
 - The diameter of the hole for the shank shall be not less than the shank diameter of the screw nor exceed it by more than 1 mm or 10% of the shank diameter, whichever is lesser.
 - The diameter of the hole for the threaded portion of the screw shall not exceed the root diameter of the screw.
 - The depth of the hole shall exceed the intended depth to which the screw is to be driven.

• - **Wall Bracket to Concrete**

- o 2 x Ramset™ WERCS Ankascrew™ Anchor, M6x50 mm (AS06050WGM100), or
- 2 x Ramset™ Ankascrew™ Anchor, M6x50 mm (AS06050GM), to be installed in accordance with Ramset™ Technical Data Sheet.
- o Minimum Concrete Strength 25 MPa,
- o Minimum Edge Distance 50 mm,
- o Minimum concrete embedment depth 39 mm.

- **Wall Bracket to Timber**

- **Option 1:** 2 x Coach Screw, M6 x (length) mm, Class 4.6 or Class 4.8 in accordance with AS/NZ 4291.1 and a hardness of 120-250 HV (67 HRB-22HRC) with:
 - o Minimum embedment depth of the threaded portion of the coach screw into the side grain of the supporting structure is not less than,
 - o 45 mm for JD3 (e.g. Seasoned, Mixed Australian Hardwoods),
 - o 50 mm for J3 (e.g. Unseasoned, Mixed Australian Hardwoods),
 - o 50 mm for JD4 (e.g. Seasoned, Mixed Softwood Species), or
 - o 60 mm for J4 (e.g. Unseasoned, Pine, Radiata, Australia).
 - o Minimum end distance (8D) 48 mm, see AS 1720.1 for definitions.
 - o Minimum edge distance (4D) 24 mm, see AS 1720.1 for definitions.
 - o The diameter of the hole for the shank shall be not less than the shank diameter of the screw nor exceed it by more than 1 mm or 10% of the shank diameter, whichever is lesser.
 - o The diameter of the hole for the threaded portion of the screw shall not exceed the root diameter of the screw.
 - o The depth of the hole shall exceed the intended depth to which the screw is to be driven.
- **Option 2:** 2 x Type 17 14g (6.3 mm) screws with ST6.3 thread in accordance with AS 3566 with:
 - o Minimum embedment depth into the side-grain of the supporting structure,

- 45 mm for JD3 (e.g. Seasoned, Mixed Australian Hardwoods),
- 50 mm for J3 (e.g. Unseasoned, Mixed Australian Hardwoods),
- 50 mm for JD4 (e.g. Seasoned, Mixed Softwood Species), or
- 60 mm for J4 (e.g. Unseasoned, Pine, Radiata, Australia).
- Minimum end distance (10D) 63 mm, see AS 1720.1 for definitions.
- Minimum edge distance (5D) 31.5 mm, see AS 1720.1 for definitions.
- The diameter of the hole for the threaded portion of the screw shall not exceed the root diameter of the screw.
- The wall bracket shall be aligned such that a line drawn between the screws is aligned across the grain.
- **'Base Rail Support' & 'Base Rail Support for Glass Panel' Brackets to Concrete**
 - 2 x Ramset™ WERCS Ankascrew™ Anchor, M5x30 mm (AS05030), to be installed in accordance with Ramset™ Technical Data Sheet.
 - Minimum Concrete Strength 25 MPa,
 - Minimum Edge Distance 40 mm,
 - Minimum concrete embedment depth 27 mm.
- **'Base Rail Support' & 'Base Rail Support for Glass Panel' Brackets to Timber**
 - 2 x Type 17 10g timber screws (4.88 mm) in accordance with AS 3566 with:
 - Minimum embedment depth into side-grain of the supporting structure (7D) 34 mm, for J1 to J4 and JD1 to JD4 (e.g. Unseasoned or Seasoned, Mixed Australian Hardwoods or Mixed Softwood Species or Pine, Radiata, Australia).
 - Minimum end distance (10D) 49 mm, see AS 1720.1 for definitions.
 - Minimum edge distance (5D) 25 mm, see AS 1720.1 for definitions.
 - The diameter of the hole for the threaded portion of the screw shall not exceed the root diameter of the screw.
 - The base rail support bracket shall be aligned such that a line drawn between the screws is aligned across the grain.